

Procedures to File a Request to the Korean Intellectual Property Office for Patent Prosecution Highway Pilot Program between the Korean Intellectual Property Office and the State Intellectual Property Office of the P. R. China

The pilot program consists of 2 sub-units: Patent Prosecution Highway using the national work products (PPH) and Patent Prosecution Highway using the Patent Cooperation Treaty work products (PCT-PPH). The pilot period will commence on March 1, 2012 for a duration of one year and ending on February 28 2013. The pilot period may be extended if necessary until the State Intellectual Property Office of the P. R. China (SIPO) and the Korean Intellectual Property Office (KIPO) receive the sufficient number of PPH/PCT-PPH requests to adequately assess the feasibility of PPH/PCT-PPH program.

The Offices may also terminate the pilot program if the volume of participation exceeds manageable level, or for any other reason. Ex Ante notice will be published if the pilot program is terminated.

Part I

PPH using the national work products from the SIPO

Applicants can request accelerated examination by a prescribed procedure including submission of relevant documents on an application which is filed with the KIPO and satisfies the following requirements under the KIPO-SIPO PPH pilot program based on the SIPO application.

When filing a request for the PPH pilot program, an applicant must submit a request form "Request for Accelerated Examination under the Patent Prosecution Highway" to the KIPO.

1. Requirements

- (a) *The KIPO application (including PCT national phase application) is*
- (i) *an application which validly claims priority under the Paris Convention to the SIPO application(s) (examples are provided in ANNEX I, Figure A, B, C, F, G and H), or*
 - (ii) *a PCT national phase application without priority claim (examples are provided in ANNEX I, Figure I and K), or*
 - (iii) *an application which validly claims priority under the Paris Convention to the PCT application(s) without priority claim (examples are provided in ANNEX I, Figure J and L).*

The KIPO application, which validly claims priority to multiple SIPO or direct PCT applications, or which is the divisional application validly based on the originally filed

application that is included in (i) to (iii) above, is also eligible.

(b) At least one corresponding application exists in the SIPO and has one or more claims that are determined to be patentable/allowable by the SIPO.

The corresponding application(s) can be the application which forms the basis of the priority claim, an application which derived from the SIPO application which forms the basis of the priority claim (e.g., a divisional application of the SIPO application or an application which claims domestic priority to the SIPO application (see Figure C in ANNEX I)), or a SIPO national phase application of a PCT application (see Figures H, I, J, K and L in ANNEX I).

Claims are “determined to be allowable/patentable” when the SIPO examiner explicitly identified the claims to be allowable/patentable in the latest office action, even if the application is not granted for patent yet.

The office action includes:

- (1) Decision to Grant a Patent
- (2) First/Second/Third/…… Office Action
- (3) Decision of Refusal
- (4) Reexamination Decision
- (5) Invalidation Decision

Claims are also “determined to be allowable/patentable” in the following circumstances: If the SIPO office action does not explicitly state that a particular claim is allowable/patentable, the applicant must include an explanation accompanying the request for participation in the PPH pilot program that no rejection has been made in the SIPO office action regarding that claim, and therefore, the claim is deemed to be allowable/patentable by the SIPO.

For example, if claims are not shown in the item of “6. the Opinion on the Conclusion of Examination (审查的结论性意见) about Claims (权利要求书)” in the “First Notice of the Opinion on Examination(第一次审查意见通知书)” or “5. the Opinion on the Conclusion of Examination (审查的结论性意见) about Claims (权利要求书)” in the “Second/Third/... Notice of the Opinion on Examination(第 次审查意见通知书)” of the SIPO, those claims may be deemed to be implicitly identified to be allowable/patentable and then the applicant must include the above explanation.

(c) All claims in the KIPO application (for which an accelerated examination under the PPH pilot program is requested), as originally filed or as amended, must sufficiently correspond to one or more of those claims determined to be patentable/allowable in the SIPO.

Claims are considered to “sufficiently correspond” where, accounting for differences due to

translations and claim format, the claims in the KIPO are of the same or similar scope as the claims in the SIPO, or the claims in the KIPO are narrower in scope than the claims in the SIPO.

In this regard, a claim that is narrower in scope occurs when a SIPO claim is amended to be further limited by an additional technical feature that is supported in the specification (description and/or claims).

A claim in the KIPO which introduces a new/different category of claims to those claims determined to be patentable/allowable in the SIPO is not considered to sufficiently correspond. For example, the SIPO claims only contain claims to a process of manufacturing a product, then the claims in the KIPO are not considered to sufficiently correspond if the KIPO claims introduce product claims that are dependent on the corresponding process claims.

It is not necessary to include “all” claims determined to be patentable/allowable in the SIPO in an application in the KIPO (the deletion of claims is allowable). For example, in the case where an application in the SIPO contains 5 claims determined to be patentable/allowable, the application in the KIPO may contain only 3 of these 5 claims.

Refer to ANNEX III for the cases which are considered to “sufficiently correspond” and the cases which are not considered to “sufficiently correspond”.

Any claims amended or added after the grant of the request for participation in the PPH pilot program need to sufficiently correspond to the claims indicated as patentable/allowable in the SIPO application when applicants have not received any office action related to substantive examination. Any claims amended or added after the grant of the request for participation in the PPH pilot program need not to sufficiently correspond to the claims indicated as patentable/allowable in the SIPO application when applicants need to amend claims in order to overcome the reasons for refusal raised by examiners.

(d) A “Request for Examination” must have been filed.

The request for accelerated examination under the PPH must be accompanied by, or preceded by a request for examination.

The request for accelerated examination under the PPH may be filed not only when examination has not begun, but also when examination has already begun.

2. Documents to be submitted

Documents (a) to (d) below must be submitted by attaching to “Request for Accelerated Examination under the Patent Prosecution Highway”.

Note that even when it is not needed to submit documents below, the name of the documents must be listed in “Request for Accelerated Examination under the Patent Prosecution Highway”

(Please refer to the example form below for the detail).

(a) Copies of all office actions (which are relevant to substantial examination for patentability in the SIPO), which were sent for the corresponding application by the SIPO, and translations of them.

Either Korean or English is acceptable as translation language. If it is impossible for the examiner to understand the translated office action, the examiner can request the applicant to resubmit translations.

(b) Copies of all claims determined to be patentable/allowable by the SIPO, and translations of them.

Either Korean or English is acceptable as translation language. If it is impossible for the examiner to understand the translated claims, the examiner can request the applicant to resubmit translations.

(c) Copies of references cited by the SIPO examiner

The documents to be submitted are those cited in the above-mentioned office actions. Documents which are only referred to as references and consequently do not consist of the reasons for refusal do not have to be submitted.

If the references are patent documents, the applicant does not have to submit them. When the KIPO does not possess the patent document, the applicant has to submit the patent document at the examiner's request. Non-patent literature must always be submitted. The translations of the references are unnecessary.

(d) Claim correspondence table

The applicant requesting PPH must submit a claim correspondence table, which indicates how all claims in the KIPO application sufficiently correspond to the patentable/allowable claims in the SIPO application.

When claims are just literal translation, the applicant can just write down that "they are the same" in the table. When claims are not just literal translation, it is necessary to explain the sufficient correspondence of each claim based on the criteria 1.(c) (Please refer to the example form below).

3. Fee

An applicant should pay the fee for the request for participation in the PPH to the KIPO.

4. Example of “Request for Accelerated Examination under the Patent Prosecution Highway” for filing request of an accelerated examination under the PPH pilot program

(a) *Circumstances*

When an applicant files a request for participation in the PPH pilot program to the KIPO, an applicant must submit a request form “Request for Accelerated Examination under the Patent Prosecution Highway”.

The applicant must indicate that the application is included in (i) to (iii) of 1. (a), and that the accelerated examination is requested under the PPH pilot program. The application number of the corresponding SIPO application(s) also must be written.

In the case that the application which has one or more claims that are determined to be patentable/allowable is different from the SIPO application(s) included in (i) to (iii) of 1. (a) (for example, the divisional application of the basic application), the application number of the application(s) which has claims determined to be patentable/allowable and the relationship between those applications also must be explained.

(b) *Documents to be submitted*

The applicant must list all required documents mentioned above 2. in an identifiable way, even when the applicant is exempted to submit certain documents.

(c) *Notice*

An applicant can file the “Request for Accelerated Examination under the Patent Prosecution Highway” to the KIPO through either paper-based or on-line procedures.

5. Procedure for the accelerated examination under the PPH

The KIPO decides whether the application can be entitled to the status for an accelerated examination under the PPH when it receives a request with the documents stated above. When the KIPO decides that the request is acceptable, the application is assigned a special status for an accelerated examination under the PPH.

In those instances where the request does not meet all the requirements set forth above, the applicant will be notified and the defects in the request will be identified. The applicant will be given opportunity to perfect the request. If not perfected, the applicant will be notified and the application will await action in its regular turn. Then the applicant may resubmit the request.

The KIPO will not notify the applicant of the acceptance for assigning a special status for accelerated examination under the PPH, but instead applicant may recognize it by the reception of an office action resulting from accelerated examination.

Example form of Request for Accelerated Examination under the Patent Prosecution Highway
(consists of 2 Forms: Request for Accelerated Examination and Explanation of Request for
Accelerated Examination under the Patent Prosecution Highway)

【서류명】 심사청구(우선심사신청)서 (Form of Request for Accelerated Examination)

【구분】 우선심사신청 (Request for Accelerated Examination)

【제출인】 (Subscriber)

【명칭】 (Name)

【출원인코드】 (Subscriber ID)

【사건과의 관계】 (Relation)

【대리인】 (Agent)

【성명】 (Name)

【대리인코드】 (Agent ID)

【포괄위임등록번호】 (Mandating Registration ID)

【사건의 표시】 (Application)

【출원번호】 (Application Number)

【발명의 명칭】 (Title)

【수수료】 (Fee)

【우선심사 신청료】 (Fee for Accelerated Examination)

【수수료 자동납부번호】 (Automated Fee Transfer ID)

【취지】 (Purpose)

【첨부서류】 (Attachment) (Explanation of Request for Accelerated Examination under the Patent
Prosecution Highway)

【서류명】 특허심사하이웨이(PPH)에 의한 우선심사신청설명서

(Explanation of Request for Accelerated Examination under the Patent Prosecution Highway)

【대상국가】 (Office of First Filing)

【본원출원번호】 (Application Number)

【대응출원번호】 (Application Number of Corresponding Application)

【본원출원과 대응출원의 관계】 (Relation of the Corresponding Application)

【제출서류】 (Required Documents)

【특허가능하다고 판단된 특허청구범위】 (Patentable Claims in OFF)

【서류명 및 제출(발행)일】 (Issue Date)

【서류제출여부】 (Submit, Y/N)

【제출생략 이유】 (Reasons of Exemption)

【번역문제출여부】 (Submit Translations, Y/N)

【제출생략 이유】 (Reasons of Exemption for Translations)

【심사관련통지서】 (Office Action in OFF)

【서류명 및 통지일】 (Issue Date)

【서류제출여부】 (Submit, Y/N)

【제출생략 이유】 (Reasons of Exemption)

【번역문제출여부】 (Submit Translations, Y/N)

【제출생략 이유】 (Reasons of Exemption for Translations)

【심사단계에서 인용된 선행기술문헌】 (Prior Arts cited in the Office Action of OFF)

【명칭】 (Title)

【제출여부】 (Submit, Y/N)

【제출생략 이유】 (Reasons of Exemption)

【청구항간 대응관계설명표】 (Claim Correspondence Table)

본원출원의 청구항 번호 (Claim Number)	대응출원에서 특허가능하다고 판단한 청구항 번호 (Claim Number of OFF)	대응관계 설명 (Correspondence)

Part II

PPH using the PCT international work products from the SIPO

Applicants can request accelerated examination by a prescribed procedure including submission of relevant documents on an application which is filed with the KIPO and satisfies the following requirements under the KIPO-SIPO PCT-PPH pilot program.

When filing a request for the PCT-PPH pilot program, an applicant must submit a request form "Request for Accelerated Examination under the PCT-PPH" to the KIPO.

1. Requirements

The application which is filed with the KIPO and on which the applicant files a request for the PCT-PPH must satisfy the following requirements:

- (a) ***The latest work product in the international phase of a PCT application corresponding to the application ("international work product"), namely the Written Opinion of International Search Authority (WO/ISA), the Written Opinion of International Preliminary Examination Authority (WO/IPEA) or the International Preliminary Examination Report (IPER), indicates at least one claim as patentable/allowable (from the aspect of novelty, inventive steps and industrial applicability).***

Note that the ISA and the IPEA which produced the WO/ISA, WO/IPEA and the IPER are limited to the KIPO or the SIPO, but, if priority is claimed, the priority claim can be to an application in any Office, see example A' in ANNEX II (application ZZ can be any national application).

The applicant cannot file a request for PCT-PPH on the basis of an International Search Report (ISR) only.

In case any observation is described in Box VIII of WO/ISA, WO/IPEA or IPER which forms the basis of a PCT-PPH request, the application will not be eligible for participating in PCT-PPH pilot program.

- (b) ***The relationship between the application and the corresponding international application satisfies one of the following requirements:***
- (i) ***The application is a national phase application of the corresponding international application. (See Figures A, A', and A'' in ANNEX II)***
- (ii) ***The application is a national application as a basis of the priority claim of the corresponding international application. (See Figure B in ANNEX II)***

- (iii) The application is a national phase application of an international application claiming priority from the corresponding international application. (See Figure C in ANNEX II)*
 - (iv) The application is a national application claiming foreign/domestic priority from the corresponding international application. (See Figure D in ANNEX II)*
 - (v) The application is the derivative application (divisional application and application claiming domestic priority etc.) of the application which satisfies one of the above requirements (i) – (iv). (See Figures E1 and E2 in ANNEX II)*
- (c) All claims on file, as originally filed or as amended, for examination under the PCT-PPH must sufficiently correspond to one or more of those claims indicated to be patentable/allowable in the latest international work product of the corresponding international application.**

Claims are considered to "sufficiently correspond" where, accounting for differences due to translations and claim format, the claims of the application are of the same or similar scope as the claims indicated to be patentable/allowable in the latest international work product, or the claims of the application are narrower in scope than the claims indicated to be patentable/allowable in the latest international work product.

In this regard, a claim that is narrower in scope occurs when a claim indicated to be patentable/allowable in the latest international work product is amended to be further limited by an additional feature that is supported in the specification (description and/or claims) of the application.

A claim of the application which introduces a new/different category of claims to those claims indicated to be patentable/allowable in the latest international work product is not considered to sufficiently correspond. For example, the claims indicated to be patentable/allowable in the latest international work product only contain claims to a process of manufacturing a product, then the claims of the application are not considered to sufficiently correspond if the claims of the application introduce product claims that are dependent on the corresponding process claims.

It is not necessary to include "all" claims determined to be patentable/allowable in the corresponding international application in an application in the KIPO (the deletion of claims is allowable). For example, in the case where the corresponding international application contains 5 claims determined to be patentable/allowable, the application in the KIPO may contain only 3 of these 5 claims.

Refer to ANNEX III for the cases which are considered to "sufficiently correspond" and the cases which are not considered to "sufficiently correspond".

Any claims amended or added after the grant of the request for participation in the PCT-PPH pilot program need to sufficiently correspond to the claims indicated as

patentable/allowable in the latest international work product when applicants have not received any office action related to substantive examination. Any claims amended or added after the grant of the request for participation in the PCT-PPH pilot program need not to sufficiently correspond to the claims indicated as patentable/allowable in the latest international work product when applicants need to amend claims in order to overcome the reasons for refusal raised by examiners.

(d) A “Request for Examination” must have been filed.

The request for accelerated examination under the PCT-PPH must be accompanied by, or preceded by a request for examination.

The request for accelerated examination under the PCT-PPH may be filed not only when examination has not begun, but also when examination has already begun.

2. Documents to be submitted

Documents (a) to (d) below must be submitted by attaching to “Request for Accelerated Examination under the PCT-PPH”.

Note that even when it is not needed to submit documents below, the name of the documents must be listed in “Request for Accelerated Examination under the PCT-PPH” (Please refer to the example form below for the detail).

(a) A copy of the latest international work product which indicated the claims to be patentable/allowable and their Korean or English translations.

If it is impossible for the examiner to understand the translated international work product, the examiner can request the applicant to resubmit translations.

(b) A copy of a set of claims which the latest international work product of the corresponding international application indicated to be patentable/allowable and their Korean or English translations.

If it is impossible for the examiner to understand the translated claims, the examiner can request the applicant to resubmit translations.

(c) A copy of references cited in the latest international work product of the international application corresponding to the application.

Documents which are only referred to as references and consequently do not consist of the reasons for refusal do not have to be submitted.

If the reference is a patent document, the applicant is not required to submit it. In case the KIPO has difficulty in obtaining the document, however, the applicant may be asked to

submit it. Non-patent literature must always be submitted. Translations of cited references are unnecessary.

(d) *A claims correspondence table which indicates how all claims in the application sufficiently correspond to the claims indicated to be patentable/allowable.*

When claims are just literal translation, the applicant can just write down that “they are the same” in the table. When claims are not just literal translation, it is necessary to explain the sufficient correspondence of each claim based on the criteria 1.(c) (Please refer to the Example form below).

3. Fee

An applicant should pay the fee for the request for participation in the PCT-PPH to the KIPO.

4. Example of “Request for Accelerated Examination under the PCT-PPH” for filing request for an accelerated examination under the PCT-PPH pilot program

(a) *Circumstances*

The applicant must indicate that the application is included in (i) to (v) of 1.(b), and that the accelerated examination is requested under the PCT-PPH pilot program. The application number(s) of the corresponding international application(s) also must be written.

(b) *Documents to be submitted*

The applicant must list all required documents mentioned above 2. in an identifiable way, even when applicant omits to submit certain documents.

(c) *Notice*

An applicant can file the “Request for Accelerated Examination under the PCT-PPH” to the KIPO through either paper-based or on-line procedures.

5. Procedure for the accelerated examination under the PCT-PPH pilot program

The KIPO decides whether the application can be entitled to the status for an accelerated examination under the PCT-PPH when it receives a request with the documents stated above. When the KIPO decides that the request is acceptable, the application is assigned a special status for an accelerated examination under the PCT-PPH.

In those instances where the request does not meet all the requirements set forth above, the

applicant will be notified and the defects in the request will be identified. The applicant will be given opportunity to perfect the request. If not perfected, the applicant will be notified and the application will await action in its regular turn. Then the applicant may resubmit the request. The KIPO will not notify the applicant of the acceptance for assigning a special status for accelerated examination under the PCT-PPH, but instead applicant may recognize it by the reception of an office action resulting from accelerated examination.

**Example form of Request for Accelerated Examination under the PCT-PPH (consists of 2 Forms:
Request for Accelerated Examination and Explanation of Request for Accelerated Examination
under the PCT-PPH)**

【서류명】 심사청구(우선심사신청)서 (Form of Request for Accelerated Examination)

【구분】 우선심사신청 (Request for Accelerated Examination)

【제출인】 (Subscriber)

【명칭】 (Name)

【출원인코드】 (Subscriber ID)

【사건과의 관계】 (Relation)

【대리인】 (Agent)

【성명】 (Name)

【대리인코드】 (Agent ID)

【포괄위임등록번호】 (Mandating Registration ID)

【사건의 표시】 (Application)

【출원번호】 (Application Number)

【발명의 명칭】 (Title)

【수수료】 (Fee)

【우선심사 신청료】 (Fee for Accelerated Examination)

【수수료 자동납부번호】 (Automated Fee Transfer ID)

【취지】 (Purpose)

【첨부서류】 (Attachment) (Explanation of Request for Accelerated Examination under the
PCT-PPH)

【서류명】 PCT-PPH 에 의한 우선심사신청설명서

(Explanation of Request for Accelerated Examination under the PCT-PPH)

【대상국가】 (Office of First Filing)

【본원출원번호】 (Application Number)

【대응출원번호】 (Application Number of Corresponding Application)

【본원출원과 대응출원의 관계】 (Relation of the Corresponding Application)

【제출서류】 (Required Documents)

【신규성, 진보성 및 산업상 이용가능성이 모두 있다고 판단된 특허청구범위】

(Patentable Claims in view of Novelty, Inventive step and Industrial Applicability)

【서류명 및 제출(발행)일】 (Issue Date)

【서류제출여부】 (Submit, Y/N)

【제출생략 이유】 (Reasons of Exemption)

【번역문제출여부】 (Submit Translations, Y/N)

【제출생략 이유】 (Reasons of Exemption for Translations)

【국제조사 또는 국제예비심사 관련 통지서】 (International Work Product)

【서류명 및 통지일】 (Issue Date)

【서류제출여부】 (Submit, Y/N)

【제출생략 이유】 (Reasons of Exemption)

【번역문제출여부】 (Submit Translations, Y/N)

【제출생략 이유】 (Reasons of Exemption for Translations)

【국제조사 또는 국제예비심사에서 인용된 선행기술문헌】 (Prior Arts cited in WO/IPER)

【명칭】 (Title)

【제출여부】 (Submit, Y/N)

【제출생략 이유】 (Reasons of Exemption)

【청구항간 대응관계설명표】 (Claim Correspondence Table)

본원출원의 청구항 번호 (Claim Number)	대응출원에서 특허가능하다고 판단한 청구항 번호 (Claim Number of the Corresponding International Application)	대응관계 설명 (Correspondence)

【국제출원에 관한 의견 관련 설명】

(Explanation for the Comments in Box VIII of the International Work Product)

ANNEX I

A

A case meeting requirement (a) (i)
- Paris route -

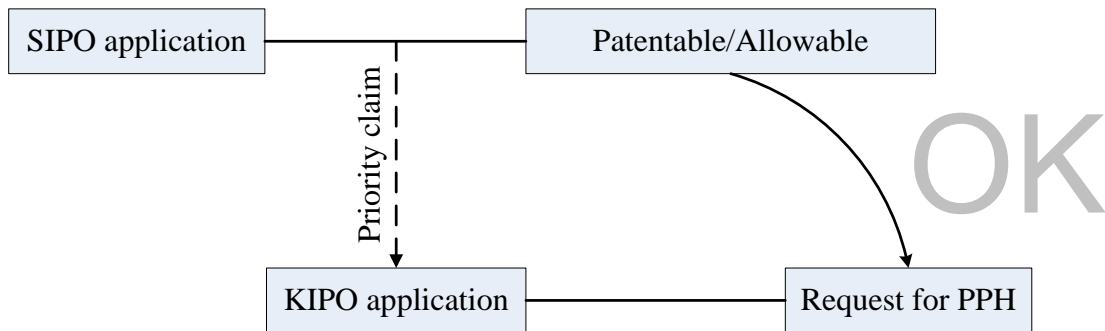

B

A case meeting requirement (a) (i)
- PCT route -

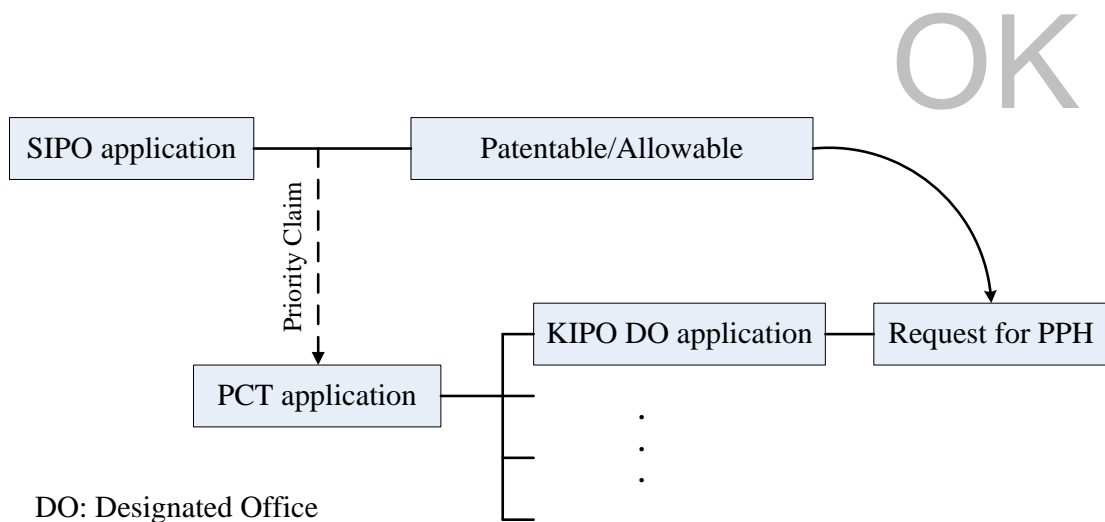

C

A case meeting requirement (a) (i)
- Paris route, Domestic priority -

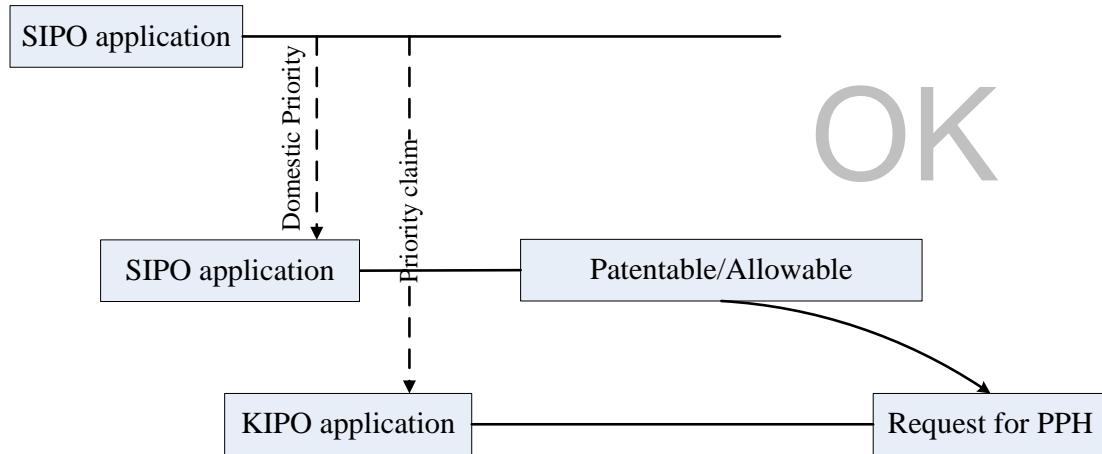

D

A case not meeting requirement (a)
- Paris route, but the first application is from the third country -

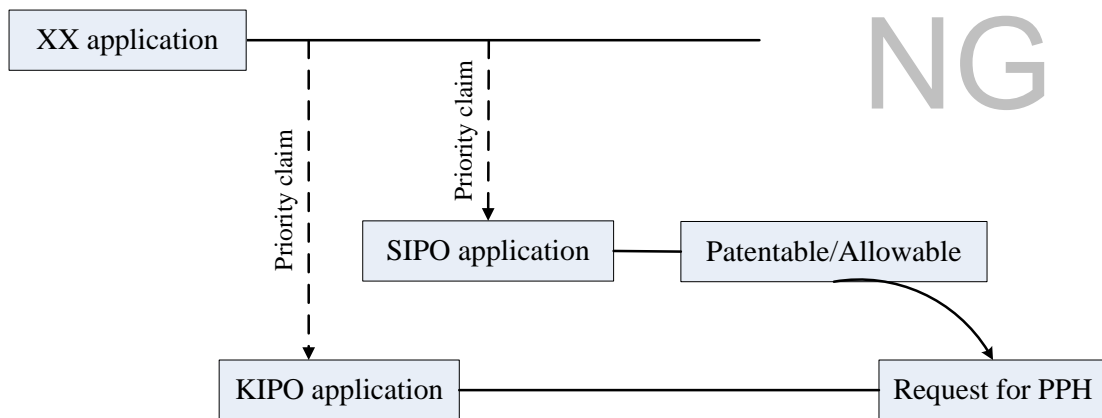

XX: the office other than the SIPO

E

A case not meeting requirement (a)
- PCT route, but the first application is from the third country -

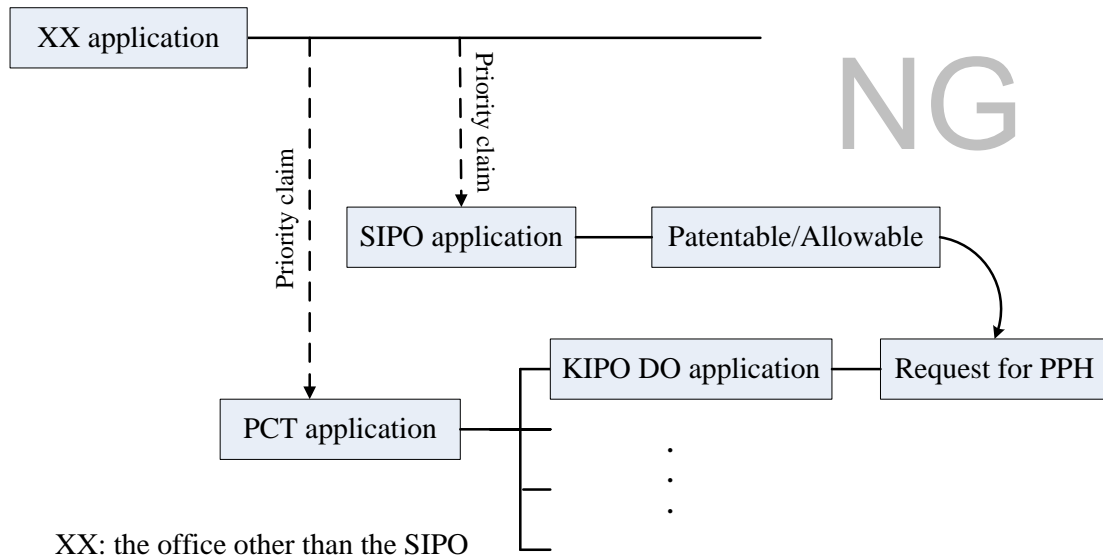

F

A case meeting requirement (a) (i)
- Paris route & complex priority -

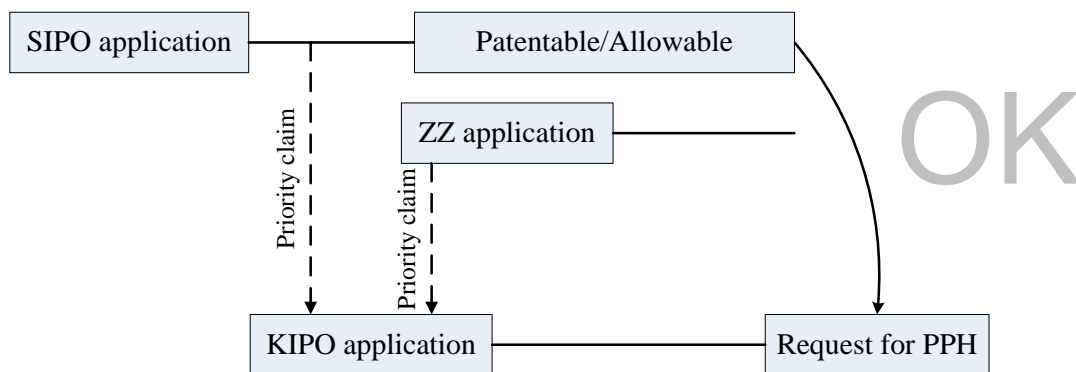

ZZ: any office

(The first application is from the SIPO)

G

A case meeting requirement (a) (i)
- Paris route & divisional application -

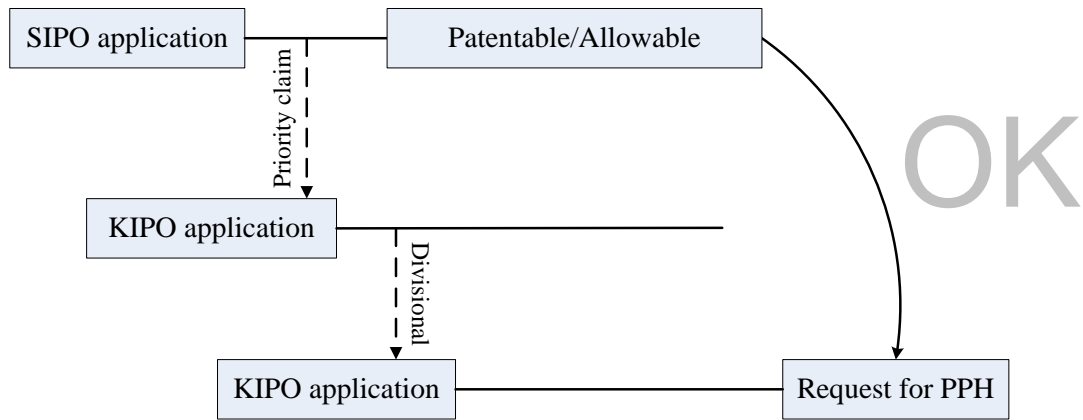

H

A case meeting requirement (a) (i)
- PCT route -

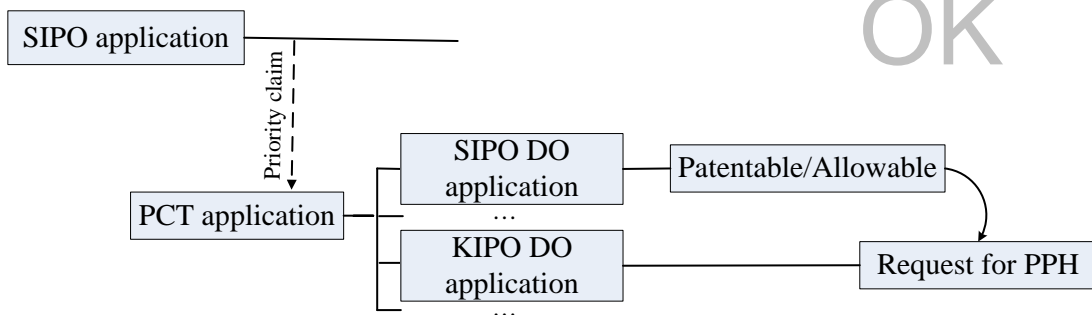

I

A case meeting requirement (a) (ii)

- Direct PCT route -

OK

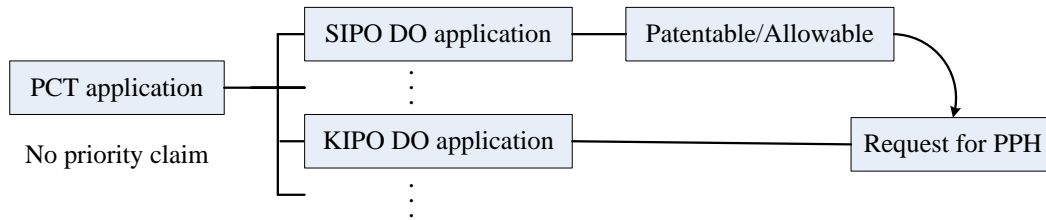

J

A case meeting requirement (a) (iii)

- Direct PCT & Paris route -

OK

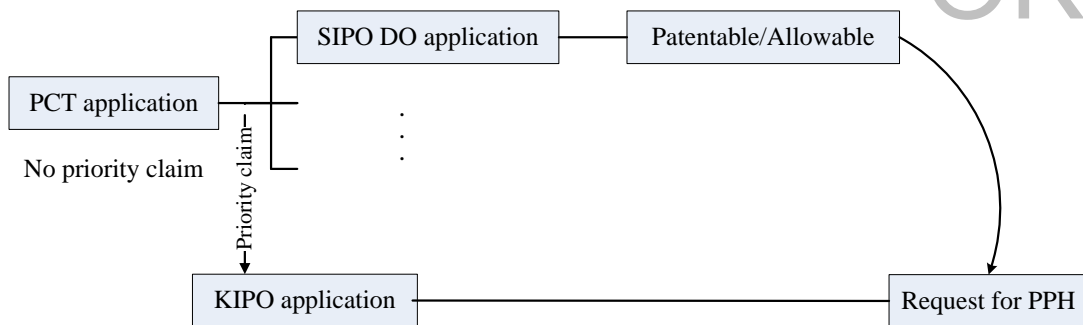

K

A case meeting requirement (a) (ii)
- Direct PCT & PCT route -

OK

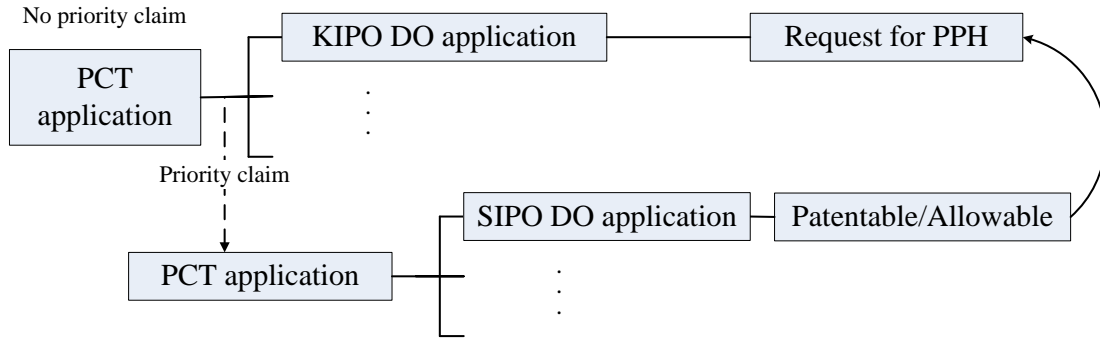

L

A case meeting requirement (a) (iii)
- Direct PCT & PCT route -

OK

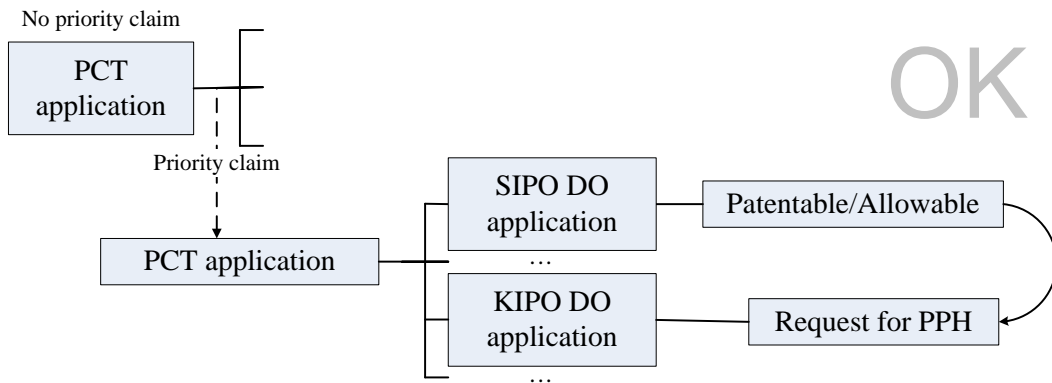

ANNEX II

(A) The application is a national phase application of the corresponding international application.

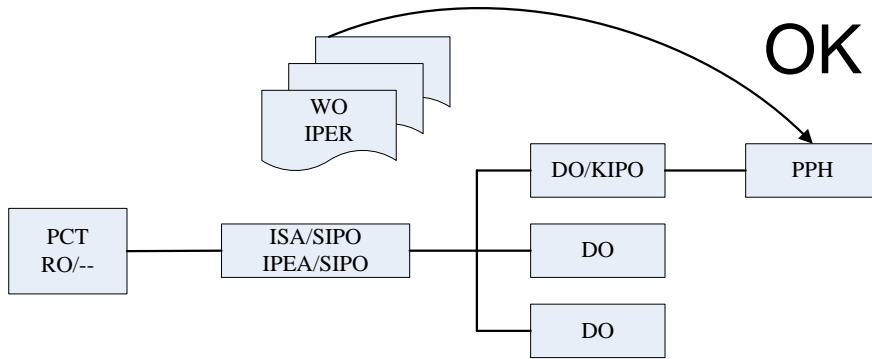

**(A') The application is a national phase application of the corresponding international application.
(The corresponding international application claims priority from a national application.)**

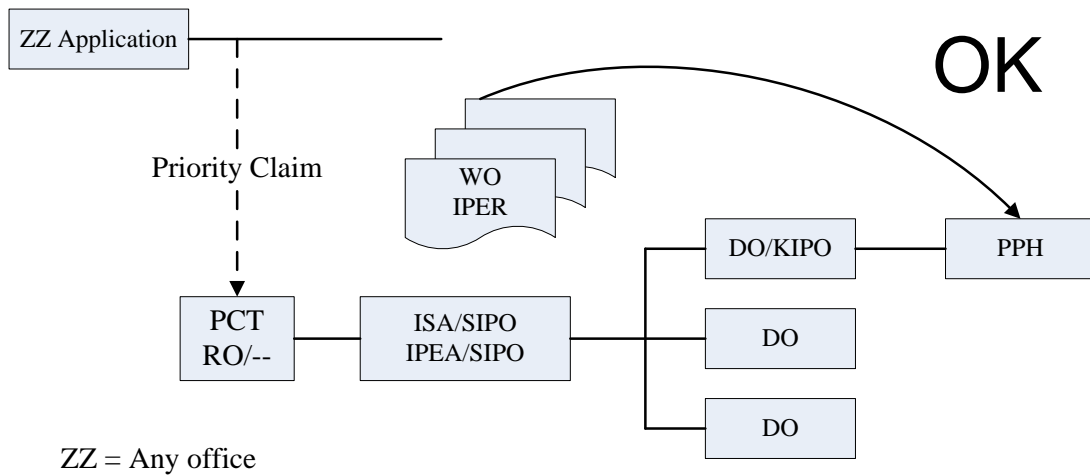

**(A'') The application is a national phase application of the corresponding international application.
 (The corresponding international application claims priority from an international application.)**

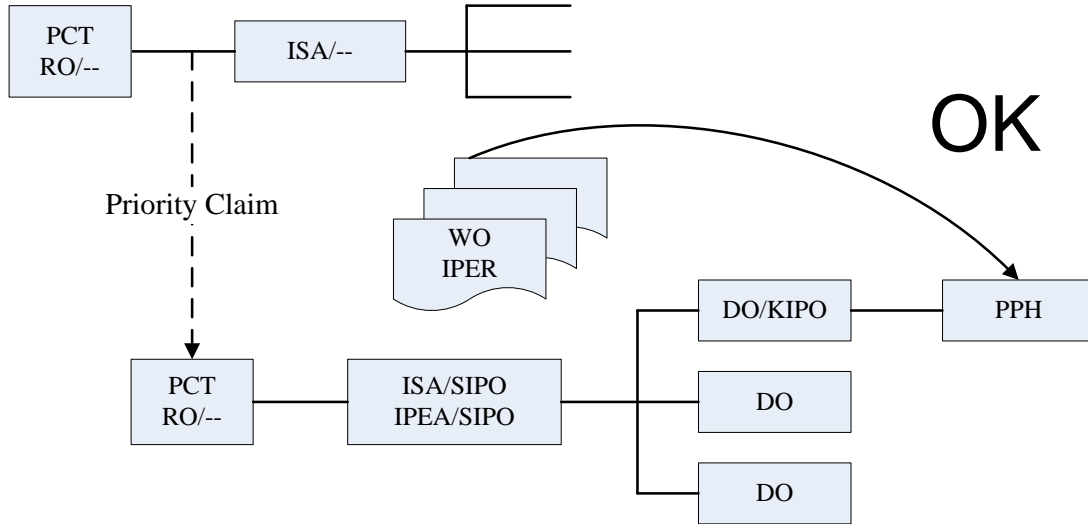

(B) The application is a national application as a basis of the priority claim of the corresponding international application.

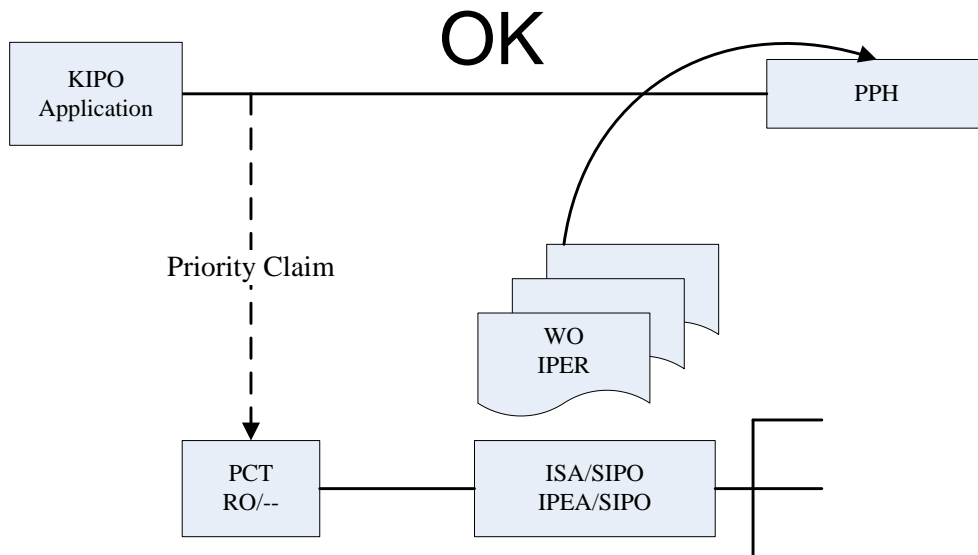

(C) The application is a national phase application of an international application claiming priority from the corresponding international application.

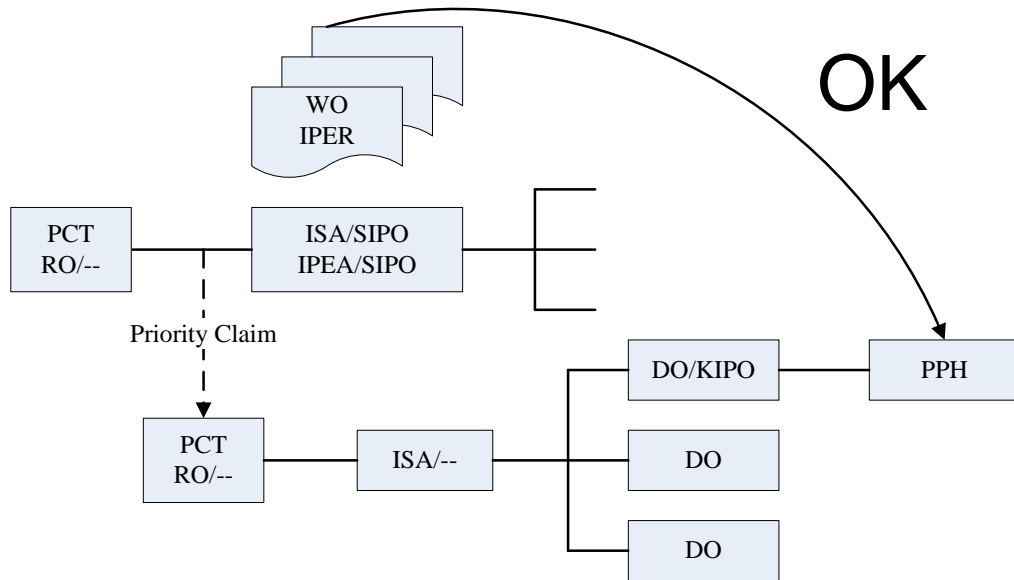

(D) The application is a national application claiming foreign/domestic priority from the corresponding international application.

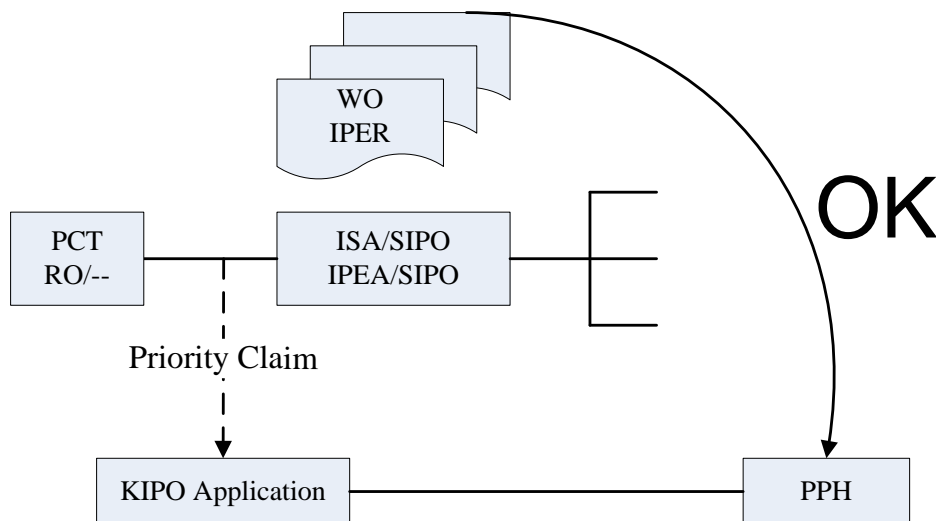

(E1) The application is a divisional application of an application which satisfies the requirement (A).

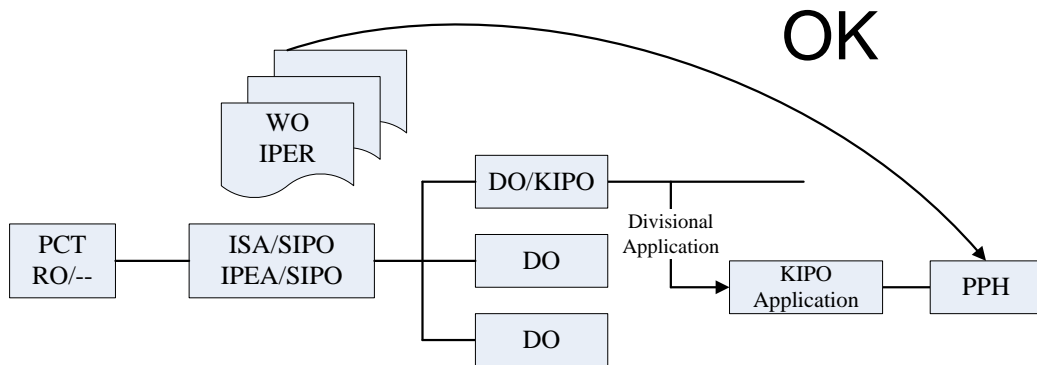

(E2) The application is an application claiming domestic priority from an application which satisfies the requirement (B).

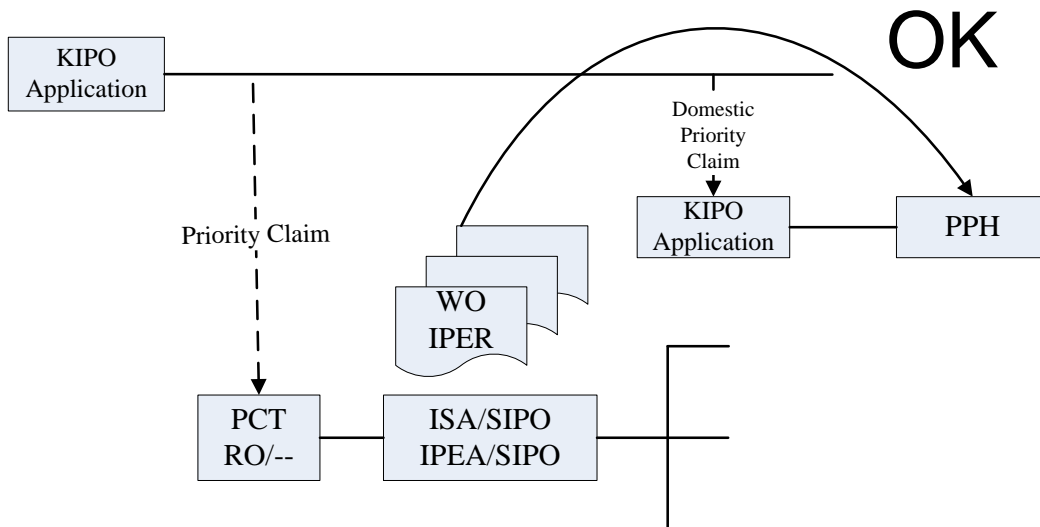

ANNEX III

Examples for the claim correspondence

1. The claims in the following cases (case 1 to case 4) are considered to “sufficiently correspond” to each other.

Case	“Patentable” claim(s)		PPH claim(s)		Correspondence
	Claim	Wording	Claim	Wording	
Case 1	1	A	1	A	PPH claim 1 is the same as “Patentable” claim 1.
Case 2	1	A	1 2	A A+a	PPH claim 1 is the same as “Patentable” claim 1. PPH claim 2 is created by adding a technical feature disclosed in the specification to “Patentable” claim 1.
Case 3	1 2 3	A A+a A+b	1 2 3	A A+b A+a	PPH claim 1 is the same as “Patentable” claim 1. PPH claims 2, 3 are the same as “Patentable” claims 3, 2, respectively.
Case 4	1	A	1	A+a	PPH claim 1 has an additional technical feature ‘a’ disclosed in the specification.

2. The claims in the following cases (case 5 and case 6) are NOT considered to “sufficiently correspond” to each other.

Case	“Patentable” claim(s)		PPH claim(s)		Explanation
	Claim	Wording	Claim	Wording	
Case 5	1	A product	1	A’ method	PPH claim 1 claims to a method, whereas “Patentable” claim 1 claims to a product. (The technical feature of “Patentable” claim is the same as that of PPH claim, but categories of both claims are different.)
Case 6	1	A+B	1	A+C	PPH claim 1 is different from “Patentable” claim 1 in a component of the claimed invention. (PPH claim is created by altering part of the technical features of “Patentable” claim.)