



Procedures to File a Request to the Korean Intellectual Property Office for Patent Prosecution Highway Pilot Program between the Korean Intellectual Property Office and the Philippine Intellectual Property Office

I. Purpose of this document

This document aims to publicize the requirements and necessary documents for requesting participation in the Patent Prosecution Highway (PPH) pilot program between the Korean Intellectual Property Office (KIPO) and the Philippine intellectual Property Office (IPOPHL) at the KIPO in order that an applicant is able to easily file a request for preferential examination under the PPH pilot program.

When an applicant files a request for preferential examination under the PPH pilot program to KIPO based on examination results by the IPOPHL as Office of Earlier Examination (OEE), the PPH request should meet the requirements described in the below paragraph III.

II. Trial Period for the PPH Pilot Program

The PPH pilot program will commence on May 1, 2015 for a period of two years ending on April 30, 2017. The offices will evaluate the results of the pilot program to determine whether and how the program should be fully implemented after the trial period.

III. Procedures to File a Request for Preferential Examination under the PPH Pilot Program

1. Basic Requirements for Requesting Preferential Examination under the PPH Pilot Program at the KIPO

There are five requirements for requesting preferential examination under the PPH pilot program at KIPO. An applicant must fulfill all five requirements listed below:

1.1 Both the KIPO application on which PPH is requested and the OEE application(s) forming the basis of the PPH request must have the same earliest date (whether this be a priority date or a filing date).

The applicant should write the earliest dates for the KIPO application and the OEE application(s) in the request form. See Annex I for examples where the above requirement is satisfied.

1.2 The corresponding application(s) in the IPOPHL has one or more claim(s) determined to be patentable/allowable by the IPOPHL

(1) The patentable/allowable claims of the IPOPHL are the claims which are explicitly identified as patentable/allowable in the granted patent publication or in the office action by the IPOPHL

(2) Corresponding application in the IPOPHL whose claims are determined to be patentable/allowable does not have to be the application for which priority is claimed in the KIPO application (the basic application). The IPOPHL application can be an application explicitly derived from the basic application, e.g., a divisional application of the basic application, a converted application of the basic application or an application which claims domestic priority to the basic application (Refer to Example D and H in Annex I).

[Note]

Where the IPOPHL application that contains the patentable/allowable claims is not the same application for which priority is claimed in the KIPO application, applicant must identify the relationship between the IPOPHL application that contains the patentable/allowable claims and the IPOPHL priority application claimed in the KIPO application.

1.3 All claims in the KIPO must sufficiently correspond or be amended to sufficiently correspond to one or more of those claims determined to be patentable/allowable in the IPOPHL.

(1) Claims are considered to “sufficiently

correspond” where the claims in the KIPO are the same or substantially same as the claims in the IPOPHL, or have additions or further limitations of specific features resulting that the claims in the KIPO fall within the scope of the claims in the IPOPHL.

A claim in the KIPO which introduces a new/different category of claims to those claims indicated as allowable in the IPOPHL is NOT considered to sufficiently correspond. For example, the IPOPHL claims only contain claims to a process of manufacturing a product, then the claims in the KIPO are not considered to sufficiently correspond if the KIPO claims introduce product claims that are dependent on the corresponding process claims.

(2) It is not necessary to include “all” claims determined to be patentable/allowable in the IPOPHL in an application in the KIPO (the deletion of claims is allowable). For example, in the case where an application in the IPOPHL contains 5 claims determined to be patentable/allowable, the corresponding application in the KIPO may contain only 3 of these 5 claims.

Refer to Annex II for the cases which are considered to “sufficiently correspond” and the cases which are not considered to “sufficiently correspond”.

1.4 Whether examination of the KIPO application has begun or not, it is possible to participate in the PPH program

It is possible to participate in the PPH not only when examination has not begun, but also when examination has already begun.

1.5 A “Request for examination” must have been filed by the applicant in order to request the preferential examination under the PPH.

The request for preferential examination under the PPH must also be accompanied by, or preceded by a request for examination.

2. Document Necessary to File a Request for Preferential Examination under the PPH Pilot Program at the KIPO.

Applicant must submit a “Request Form for Accelerated Examination” and “The Explanation of Request for Accelerated Examination under the PPH”. The documents 2.1 to 2.4 below must be submitted by attaching them to “The Explanation of Request for Accelerated Examination under the PPH.” Please refer to the ANNEX III for “Request Form for Accelerated Examination” and “The Explanation of Request for Accelerated Examination under the PPH”.

2.1 A Copy and translation of all claims determined to be patentable/allowable by the IPOPHL

(1) An applicant who requests participation in the PPH is required to submit the copy of the claims determined to be patentable/allowable in the IPOPHL.

The copy of the claims determined to be patentable/allowable by the IPOPHL might be either:

i) a copy of the document submitted at initial filing which includes claims determined to be patentable/allowable where no later amendments to the claims

have been made, or

ii) a copy of the amendments which includes claims determined to be patentable /allowable where later amendments to the claims have been made, or

iii) a copy of the IPOPHL's publication of the granted patent.

(2) Korean or English is acceptable as a translation language. If it is impossible for the examiner to understand the translated claims due to inadequate translation, the examiner can request the applicant to resubmit translations. It is noted that a request for the PPH is not rejected on the basis that the translation is not sufficient to understand the scope of the claims.

2.2 Copies and translation of all office actions in the IPOPHL

(1) An applicant who requests participation in the PPH is required to submit copies of the office actions in the IPOPHL.

“Office action” means documents which relate to examination and which were sent to an applicant from the IPOPHL examiner.

The office actions in the IPOPHL are:

- communications of the examiner (=Pruefungsbescheide). Please note that if claims are not deemed patentable in the communications of the examiner and are amended afterwards, the final decision to grant a patent (= Erteilungsbeschluss) has to be provided; or

- an isolated search report (=isolierter Recherchebericht) followed by the final decision to grant a patent .

(2) Korean or English is acceptable as a translation language. If it is impossible for the examiner to understand the translated office actions due to inadequate translation, the examiner can request the applicant to

resubmit translations. It is noted that a request for the PPH is not rejected on the basis that the translation is not sufficient to understand the scope of the office actions.

2.3 Documents cited by the IPOPHL examiner

(1) The documents to be submitted are those cited in the office action in the reason of refusal in the IPOPHL. Documents which are only referred to as references and consequently do not take part of the reason for refusal do not have to be submitted.

(2) If the cited document is a patent document, applicant does not have to submit it because it is usually available to the KIPO. However, if the cited document is non-patent literature, applicant will have to submit it.

[Note]

In the case where the KIPO examiner has difficulty in obtaining the document, it will ask the applicant to submit it. In every case, translations of the cited documents are not required.

2.4 Claim correspondence table

(1) An applicant must submit a claim correspondence table to explain the correspondence of claims determined to be patentable/allowable in the IPOPHL and all claims in the KIPO.

(2) An applicant must explain how all claims in the KIPO application sufficiently correspond to the patentable/allowable claims in the IPOPHL application in the table for each KIPO claims based on the criteria in

“III.1.3 All claims in the KIPO must sufficiently correspond to one or more of those claims determined to be patentable/allowable in the IPOPHL” (Also refer to Annex II for the examples of the claim correspondence).

3. Fee for Participation in the PPH

An applicant must pay the fee for preferential examination under the PPH same as other request for preferential examination.

4. Notes on Examination Procedures

The KIPO decides whether the application can undergo preferential examination under the PPH when it receives a request along with the documents stated above. When the KIPO decides that the request is acceptable, the application is assigned a special status for a preferential examination under the PPH.

The KIPO will not notify the applicant of the acceptance for assigning a special status for preferential examination under the PPH, but instead applicant may recognize it by the reception of an office action resulting from preferential examination.

In those instances where the request does not meet all the requirements set forth above, applicant will be notified and the defects in the request will be identified. Applicant may be given opportunity to perfect the request or may be required to submit a new request. If the PPH request is rejected, the applicant will be notified and the application will await examination in its regular turn.

ANNEX I

Examples of KIPO application eligible for the PPH

CASE I (Figure A, B, C and D)

KIPO application which validly claims priority under the Paris Convention from the OEE application(s).

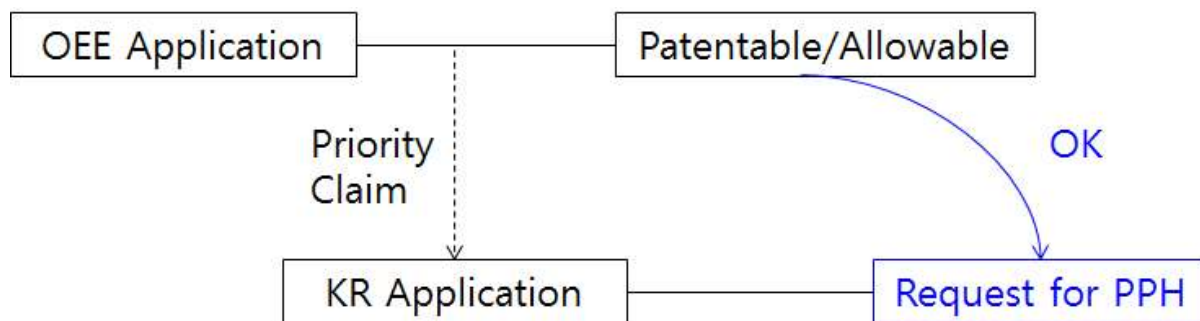

(A) Paris route

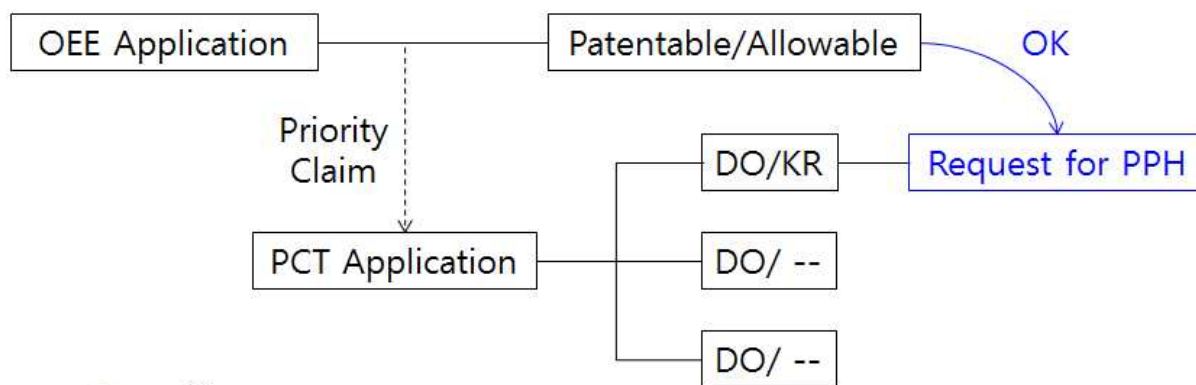

-- : Any office

(B) Paris route and PCT route

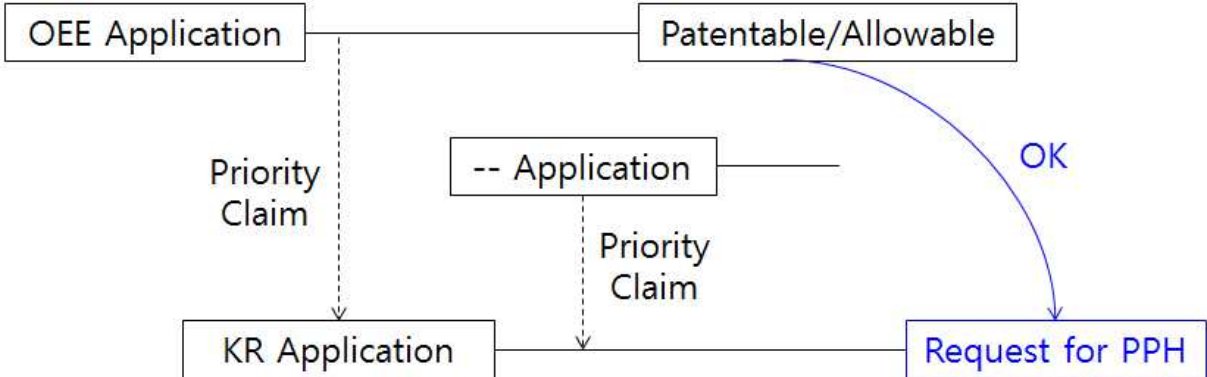

-- : Any office

(C) Paris route and complex priority

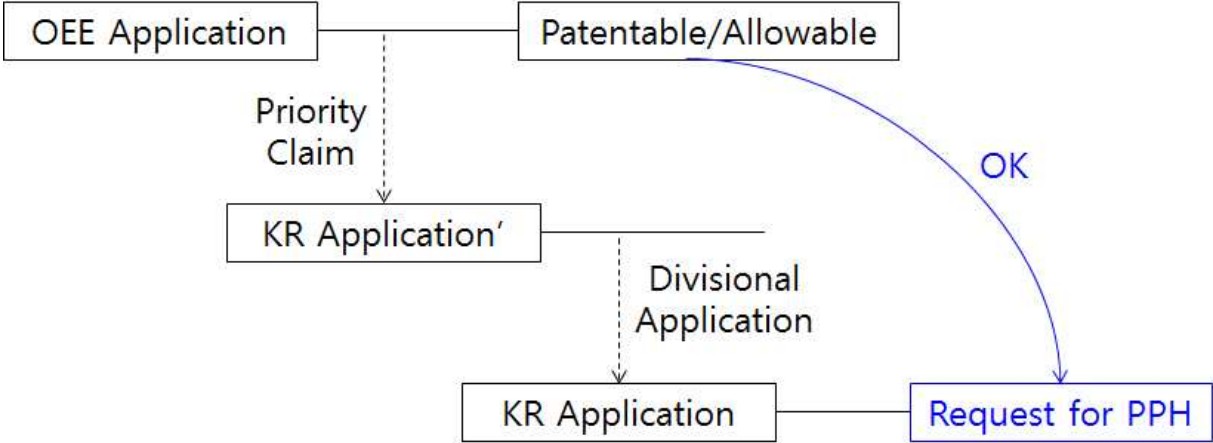

(D) Paris route and divisional application

CASE II (Figure E and F)

KIPOO application which provides the basis of a valid priority claim under the Paris Convention for the OEE application(s) (including PCT national phase application(s)).

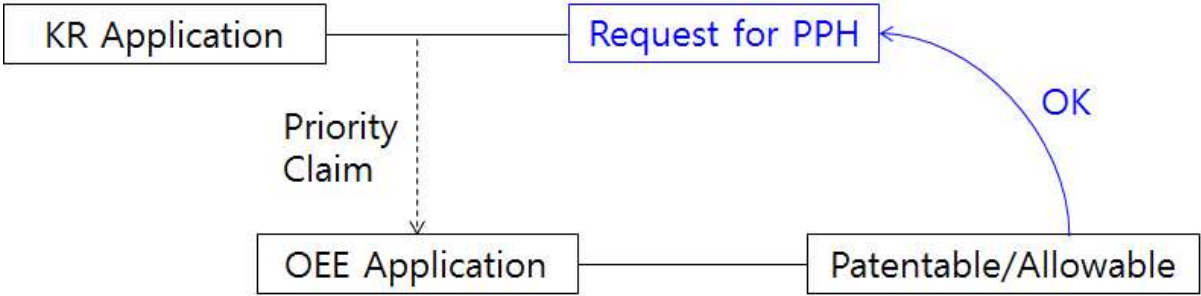

(E) Paris route

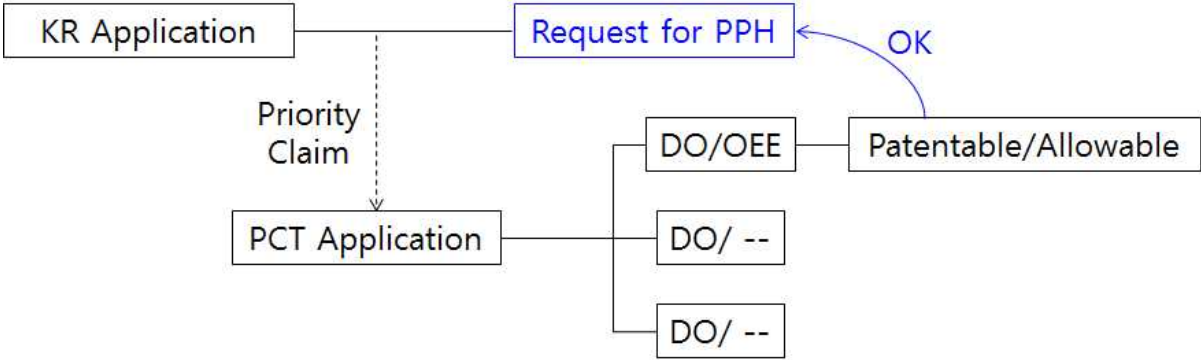

-- : Any office

(F) Paris route and PCT route

CASE III (Figure G, H, I, J, K, L and M)

KIPO application which shares a common priority document with the OEE application(s) (including PCT national phase application(s)).

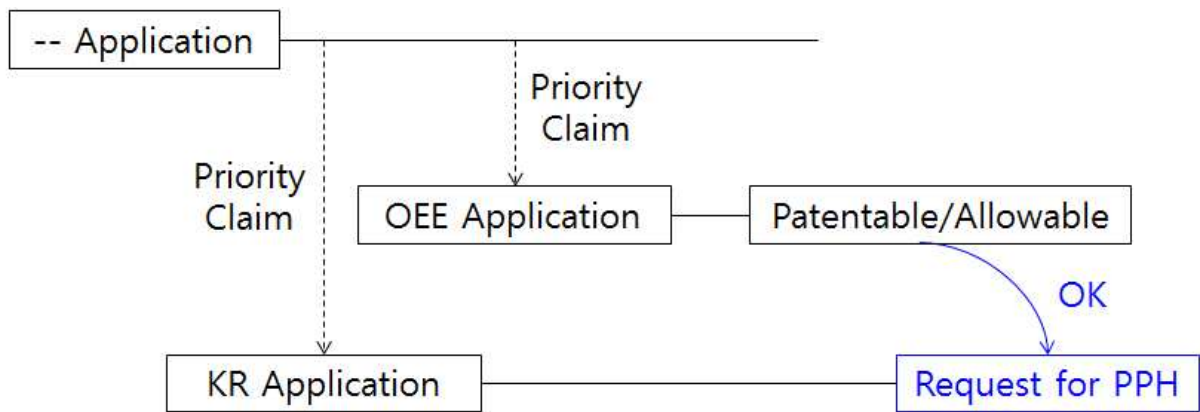

-- : Any office

(G) Paris route, but the first application is from the third country

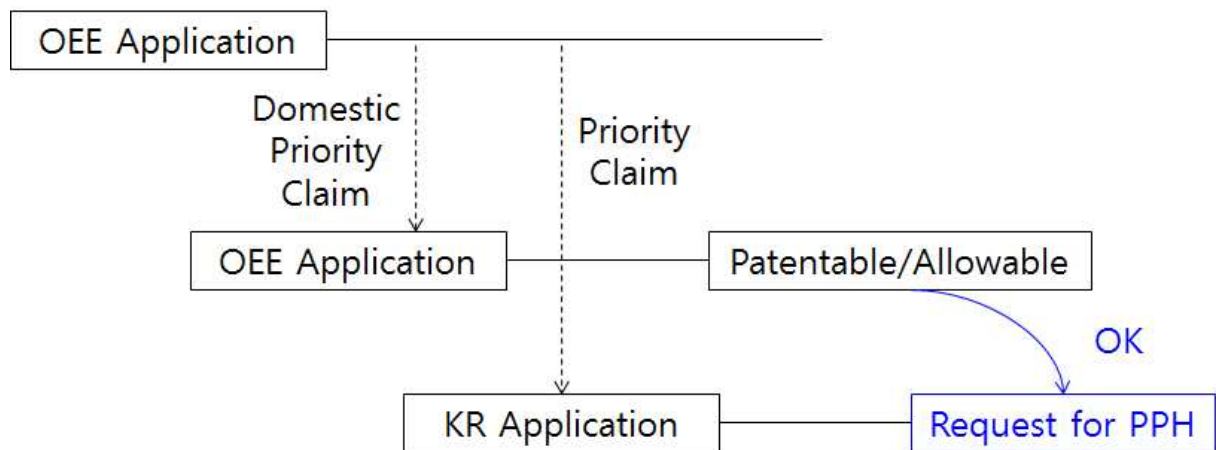

(H) Paris route and domestic priority

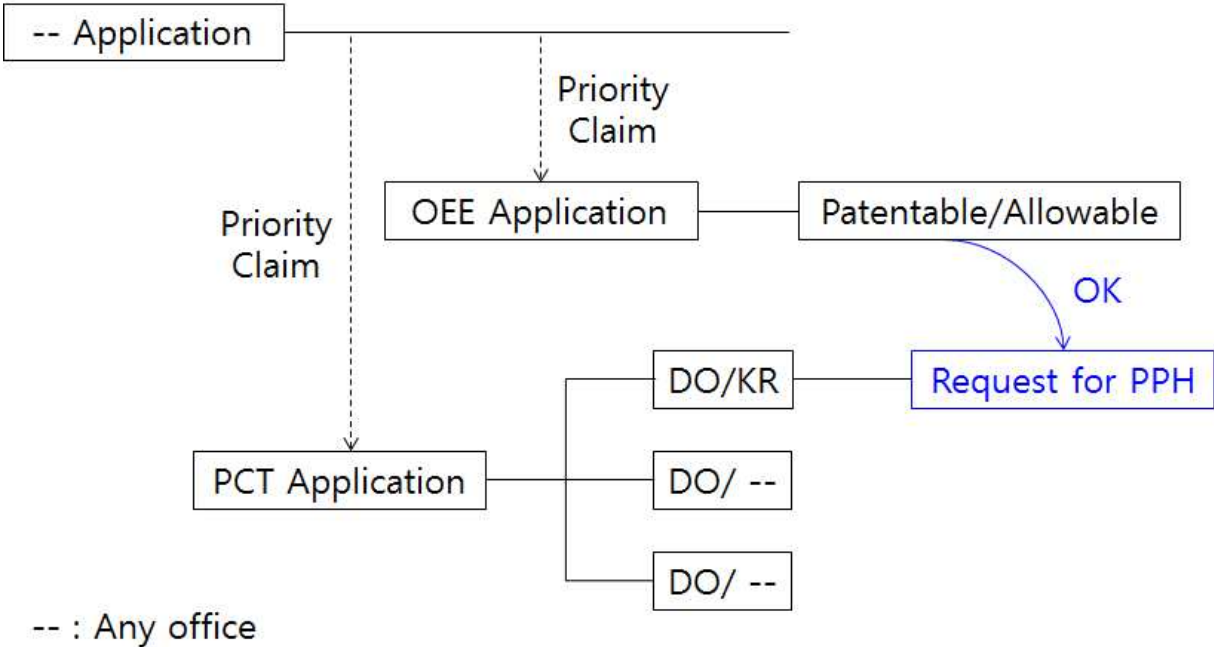

(I) Paris route and PCT route, but the first application is from the third country.

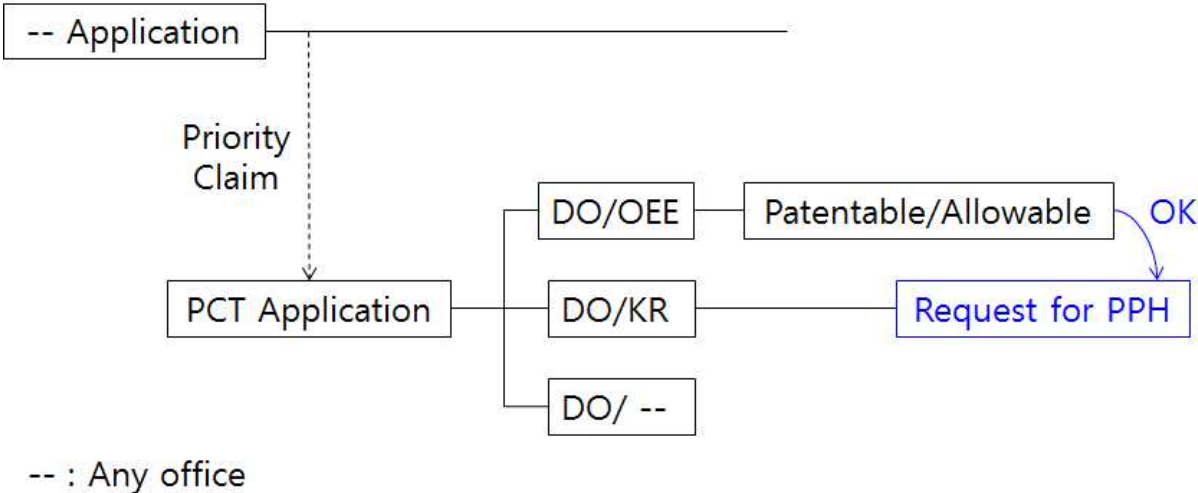

(J) PCT route

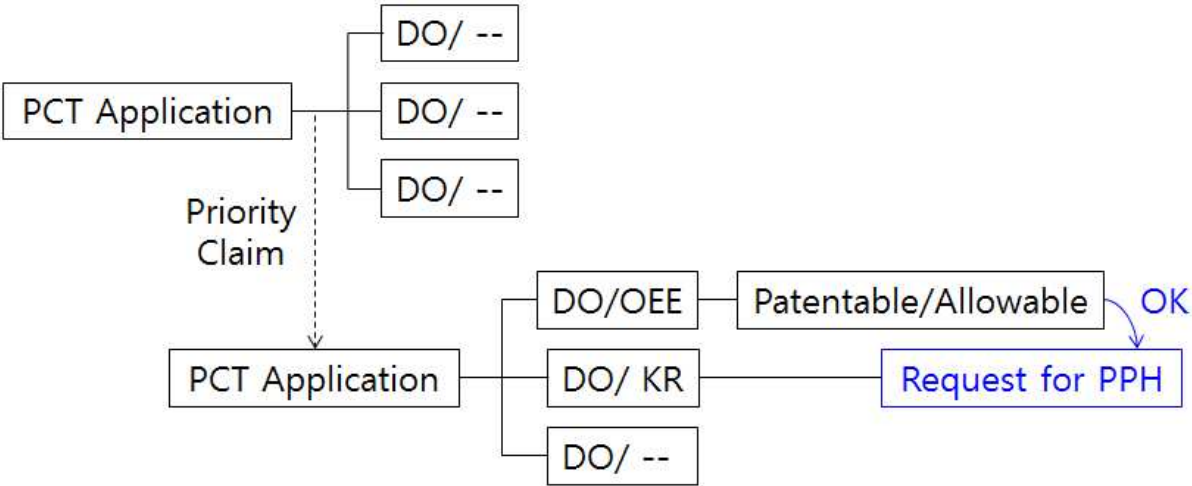

-- : Any office

(K) Direct PCT route and PCT route

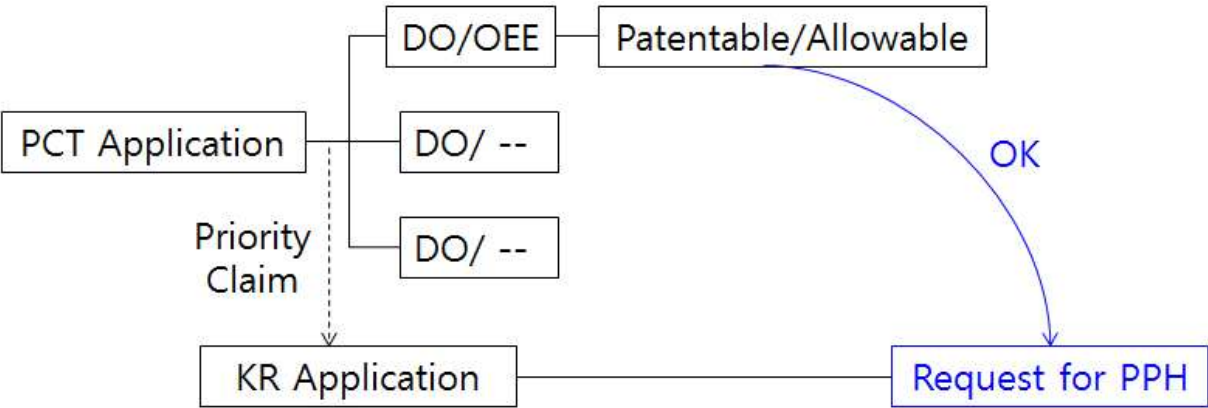

-- : Any office

(L) Direct PCT route and Paris route

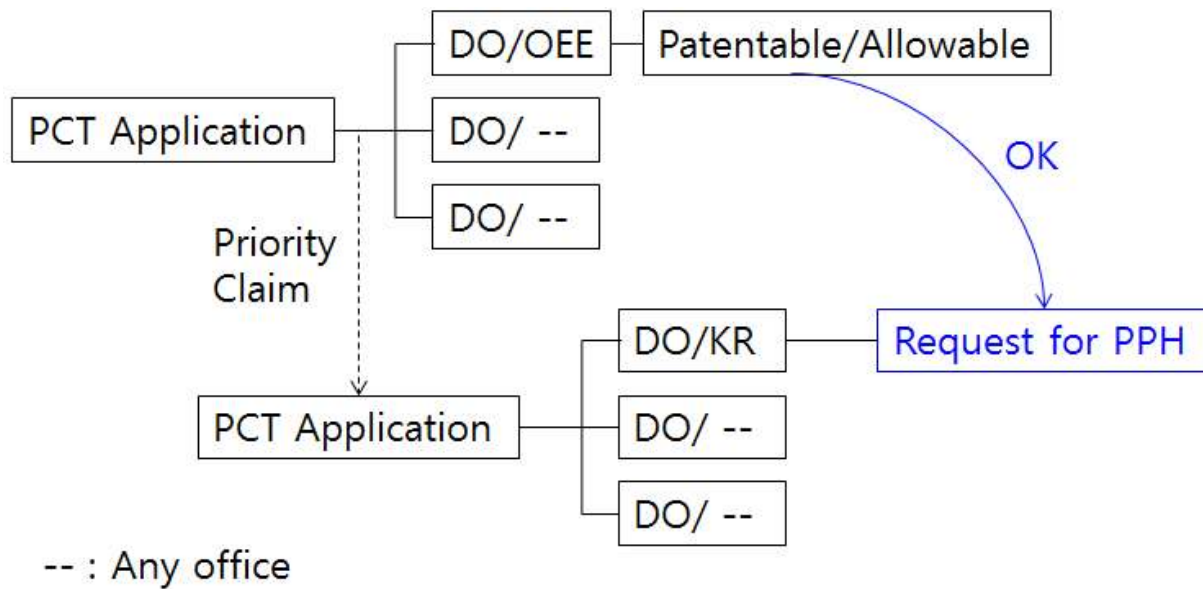

(M) Direct PCT route and PCT route

CASE IV (Figure N)

A PCT national phase application where both the KIPO application and the OEE application(s) are derived from a common PCT international application with no priority claim.

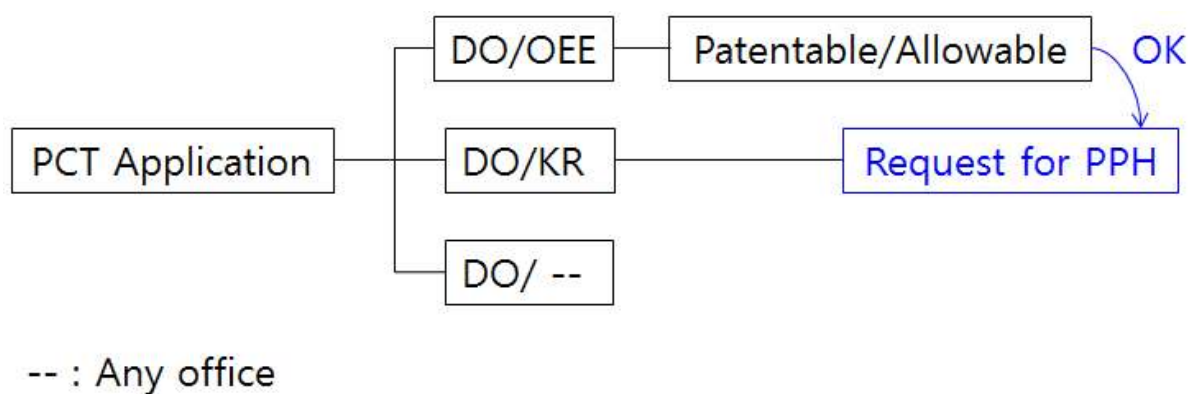

(N) Direct PCT route

ANNEX II

Examples for the claim correspondence

1. The claims in the following cases (case 1 to case 4) are considered to “sufficiently correspond” to each other.

Case	IPOPHL claim(s)		KIPO claim(s)		Correspondence
	Claim	Subject matter	Claim	Subject matter	
Case 1	1	A	1	A	The same as IPOPHL claim 1.
Case 2	1	A	1 2	A A+a	The same as IPOPHL claim 1. Dependent claim 2 in the KIPO claim is created by adding an element to the IPOPHL claim.
Case 3	1 2 3	A A+a A+b	1 2 3	A A+b A+a	The same as IPOPHL claim 1. The same except for claim format. The same except for claim format.
Case 4	1	A	1	A+a	Claim 1 has an additional element ‘a’.

** Where “A” is the subject matter, and “a” and “b” are the additional technical features which are supported in the description*

2. The claims in the following cases (case 5 and case 6) are NOT considered to “sufficiently correspond” to each other.

Case	IPOPHL claim(s)		KIPO claim(s)		Explanation
	Claim	Subject matter	Claim	Subject matter	
Case 5	1	A system	1	A' method	The claimed invention of the KIPO application is a method, whereas the claimed invention of the IPOPHL application is a system. (The technical features in the IPOPHL claim are the same as those in the KIPO claim, but categories of both inventions are different)
Case 6	1	A+B	1	A+C	The KIPO claim is different from the IPOPHL granted claim in a component of the claimed invention. (The KIPO claim is created by altering part of the technical features of the IPOPHL claim)

ANNEX III

Example form of “Request for Accelerated Examination under the Patent Prosecution Highway”

【서류명】 심사청구(우선심사신청)서 (Form of Request for Accelerated Examination)

【구분】 우선심사신청 (Request for Accelerated Examination)

【제출인】 (Subscriber)

【명칭】 (Name)

【출원인코드】 (Subscriber ID)

【사건과의 관계】 (Relation)

【대리인】 (Agent)

【성명】 (Name)

【대리인코드】 (Agent ID)

【포괄위임등록번호】 (Mandating Registration ID)

【사건의 표시】 (Application)

【출원번호】 (Application Number)

【발명의 명칭】 (Title)

【수수료】 (Fee)

【우선심사 신청료】 (Fee for Accelerated Examination)

【수수료 자동납부번호】 (Automated Fee Transfer ID)

【취지】 (Purpose)

【첨부서류】 (Attachment) (Explanation of Request for Accelerated Examination under the Patent Prosecution Highway)

【서류명】 특허심사하이웨이 (PPH)에 의한 우선심사신청설명서

(Explanation of Request for Accelerated Examination under the Patent Prosecution Highway)

【대상국가등】 (Office of Earlier Examination; OEE)

【본원출원번호】 (Application Number)

【대응출원번호】 (Application Number of Corresponding Application)

【본원출원과 대응출원의 관계】 (Relation of the Corresponding Application)

【제출서류】 (Required Documents)

【특허가능하다고 판단된 특허청구범위】 (Patentable Claims in OEE)

【서류명 및 제출(발행)일】 (Issue Date)

【서류제출여부】 (Submit, Y/N)

【제출생략 이유】 (Reasons of Exemption)

【번역문제출여부】 (Submit Translations, Y/N)

【제출생략 이유】 (Reasons of Exemption for Translations)

【심사관련통지서】 (Office Action in OEE)

【서류명 및 통지일】 (Issue Date)

【서류제출여부】 (Submit, Y/N)

【제출생략 이유】 (Reasons of Exemption)

【번역문제출여부】 (Submit Translations, Y/N)

【제출생략 이유】 (Reasons of Exemption for Translations)

【심사단계에서 인용된 선행기술문헌】 (Prior Arts cited in the Office Action of OFF)

【명칭】 (Title)

【제출여부】 (Submit, Y/N)

【제출생략 이유】 (Reasons of Exemption)

【청구항간 대응관계설명표】 (Claim Correspondence Table)

본원출원의 청구항 번호 (Claim Number)	대응출원에서 특허가능하다고 판단한 청구항 번호 (Claim Number of OEE)	대응관계 설명 (Correspondence)